



# SHORELINE

Raintree Lake Property Owners Association

May 2021

## Special points of interest:

- Sound Off—5
- Sticker placement guide—6,7
- Home Improvement Approval—9
- Close Gate at Boat Ramp—10
- Got Potholes??—11
- Raintree Rays—12
- Raintree Pool Hours—13
- Babysitter/Caregiver/House Sitter Pass—13
- Raintree ID Troubles?—13
- Lake Cleanup—15
- Spring Scattergories—17
- Keep Dues up to Date—18
- Welcome Baskets—20
- New Residents—20
- Memorial Day Fishing Derby—23
- Origin of Mother's Day—24
- Mother's Day Word Search—25

Raintree Billing for 2nd quarter has been mailed out in April and will be due by June 30th. Payments can be mailed in or dropped in the mail slot to the right of the office door.

Keep your dues up to date so you and your family can enjoy the pool and other summer activities at Raintree (once they are able to start up again!)

In This Issue:  
Financial Status - 2  
Calendar - 14  
Teens for Hire - 22

## Annual Meeting Results

Congratulations to our new Board Members and  
**THANK YOU** to those who took the time to vote!  
Congratulations also to the elected officers for the Board!

### Class A Results for Board of Directors:

Shawn Sundeen, 295  
Charlie Burke, 242

### Class B Results for Board of Directors:

Mike Conway, 26 votes

### Boats & Trailers in Driveway, PASSED

For—351, Against—125,  
Abstain—25

Congratulations to those elected as  
Officers on the 2021-2022 Raintree  
Board of Directors:

President: Daniel Merrick

Vice President: Charlie Burke

Secretary: David York

Treasurer: Marsha Powell



## Board of Directors

### Breaking Ground for the Storm Water Project !



# Financial Statement

As of March 2021

**Money Market Sweep Account:**  
\$809,624.51

**Income:**  
\$165,167.66

**Expenses:**  
\$154,458.35

**2020 Roll-Over Funds:**  
\$84,472.00

**Future Projects:**  
**Facilities:**  
\$15,000

**Raintree View:**  
\$21,550

**Siltation Loan:**  
(\$45,000)

**Ward Road:**  
\$10,000



# Delinquency Report Comparison

2021	2020
<b>One Quarter Past Due:</b>	
35 Lots totaling \$4,059.36	41 Lots totaling \$4,686.15
<b>Two Quarters Past Due:</b>	
27 Lots totaling \$7,172.80	29 Lots totaling \$7,589.00
<b>Three Quarters Past Due:</b>	
6 Lots \$2,193.66	1 Lot \$205.02
<b>Liens:</b>	
13 Lots totaling <b>\$26,884.33</b>	20 Lots totaling <b>\$32,883.48</b>

## Board Approvals for April 13, 2021

- ◆ Approved Landscaping North Shore Medians budgeted up to \$4,000.00
- ◆ Approved Clubhouse, Raintree Circle, Gull Point Circle for Landscape Lighting budgeted up to \$7,000.00
- ◆ Approved Insurance Renewals budgeted up to \$52,000.00
- ◆ Approved Maintenance Roof Replacement by Pyramid Roofing budgeted up to \$19,000.00
- ◆ Approved Rules for boats & boat trailers in driveway. See page 4
- ◆ Approved Reward for the arrest & conviction of LSPD case # 21-1991



# Unsatisfied Judgments/Liens

LIENS			
Lot#	First Name	Last Name	Address
63	Phillip	Williams	3857 SW Harbor Court
256	Kimberly	Grigsby	4068 SW Marline Dr.
295	Brett	Lloyd	4069 SW Pendant Dr.
419	John	O'Rourke	4073 SW Camelot Dr.
831	Randy & Lori	Johnson	5107 SW Pelican Pt.
862	Teresa	Lamaster	5108 SW Mallard Point
RLV5B	Diana	Wiedenmann	4140 SW Minnesota

UNSATISFIED JUDGMENTS			
Lot#	First Name	Last Name	Address
43	Angela	Marks	3829 SW Harbor Circle.
341	Skip & Barbie	McNeil	3949 SW Batten Dr.
1053	Corey	McDonald	4424 SW Gull Point
NS04	Tim	Fortier	4468 SW Raintree Shore Dr.
NS24	Brian	Morgan	4477 SW Aft

Plus 1 additional property that is in bankruptcy.

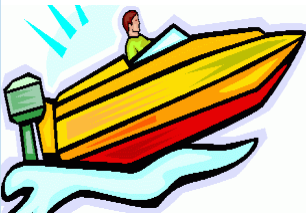

## WATER PATROL HIRING

Raintree Lake Property Owners Association is looking for Water Patrol Officers for this summer. The duties of the job include but are not limited to patrolling bodies of water to enforce the rules of the lake, checking fishermen, towing vessels, minor mechanical fixes, dock work, and overall interaction with our residents on the water. CPR and AED experience preferred. Applicants need to fill out an employment application on our website [rlpoa.com](http://rlpoa.com). So if you are looking for a fast-paced seasonal job the application is located under the resident tab, click forms and employment application. Pay negotiable with experience.

Please send the completed application and resume to [jcresswell@rlpoa.com](mailto:jcresswell@rlpoa.com).



## WANTED: Skilled Grounds Maintenance Technician to fill an immediate position

Raintree is looking for a self-motivated, driven individual, physically capable of performing various responsibilities in a fast-paced environment with minimum supervision. Must possess effective multi-tasking, managerial, organizational and problem-solving skills. Good oral and written communication skills are a necessity.

Grounds Technician is responsible for properly diagnosing and performing repairs and maintenance on all grounds equipment (gas, diesel and small engine.)

Experience in operating a variety of equipment including tractors, mowers, chainsaws, and weed eaters, to assist in various grounds keeping duties. Landscape experience preferred.

Pay range based on experience. High School Diploma or GED required. Valid Drivers License needed.

Application available in the office or on the website: [www.rlpoa.com](http://www.rlpoa.com)

# Rules for “Boats in Driveway”

At the Annual Meeting, residents voted to allow watercraft and their boat trailers to be parked in the driveway during the boating season from April 1 through October 31st. These will be voted on annually at our Annual Meeting. A few rules to follow:



- ◆ Watercraft has to be in **operable condition**
- ◆ There must be a **current Raintree Sticker** visible
- ◆ Resident must be in good standing

The Board wants you to be aware that you should **secure any items that may be stored in your watercraft**. With the potential of theft, do not give them easy targets. Secure your valuables! Watercraft that are inoperable, not allowed on Raintree Lake, have no current sticker, are not “boat trailers” or being used for boats, the 72 hour rule will be enforced. If you have any questions, please contact the office.

## Attention All Committees, Groups & Clubs

Jackson County Health Dept. has opened up rules for occupancy and along with this good news many are choosing to get vaccinations. So let's get back to a New Normal 😊

1. We will provide you sanitizing products to clean after your meeting or event. If someone is insecure with the cleanliness upon coming in, sanitize away before you sit down. Let's keep germs at bay for everyone's sake.
2. Health Dept. still states to mask up and social distance, so be prepared to put everyone at ease and bring your mask. Until there is a level of confidence within your group, be polite for everyone.
3. Buildings will start being open and available **beginning Monday May 3rd.** Reminder of our hours of operation. Monday-- Thursday 9am—5pm for the summer. If keys are required, don't forget to coordinate a pick-up with the office.
4. Now ready, set go...



### 2021 Shoreline Ad Rates

Business Card - \$47.25  
1/4 Page - \$94.50  
Half Page - \$189.00  
Full Page - \$378.00  
Business Classified - \$36.75  
**FULL COLOR AD**  
Back Cover, Half Page—\$262.50

20% Discount for  
Raintree residents

May 1, 2021

To All Residents;

Re: RLPOA Employees

I realize the grounds staff and lake patrolmen tend to be visible as they are out on the property, but they do have direction from their supervisors. If something of concern is observed on the docks or common area, report the concern to the office at 537-7576 or lake patrol at 520-3893. In an emergency call 911.

Before offering advice, criticism, or requesting additional work to be performed, contact the appropriate employee's supervisor or office. Someone else's guidance, regardless of how sincere, leaves an employee not knowing how to respond, and if it is aggressive in nature, leaves them in a quandary. Employees should never be made the middle person of a conflict on how best to handle a project or situation. Unless something is deemed an "emergency," where lives and/or property are at risk, everything should be able to wait for normal business hours.

Please understand the complex situation and balance that an employee of the Association has to deal with on a day-to-day basis.

Compliments are accepted by anyone and everyone. We all appreciate a kind word.

Below are listed the supervisors of each area.

Grounds Staff – Tara Rew, Grounds Manager (537-7576)

Lake Patrol – TBD (520-3893)

Office Staff/Pool – Josh Cresswell, Asst. General Manager (537-7576)

Thank you for your assistance.

Rachelle Vandiver  
General Manager

## SOUND OFF!

Over 32 days, I picked up 1,504 pieces of trash in Raintree Lake. The most common items I found were nerf darts, straws, plastic bags, cigarette butts, plastic cups, and empty beer cans.

Resident of 12 years

**PLEASE NOTE:** EVEN if you sub-leased someone else's boat slip the previous year you will still need to come in to the office EVERY year and sign a boat slip sub-lease form. Both the original boat slip holder and the sub-lessee will need to sign the paperwork.



### Procedures for Residents with NEW and USED WATERCRAFT for Raintree Lake

If you have a new motorized watercraft please get your title, registration or bill of sale with a copy of your declaration page for your insurance into the office as soon as possible. The insurance declaration page needs to have RLPOA as an additional interested party with our address of 825 SW Raintree Drive, Lee's Summit, MO 64082. The turn around time frame will be up to 7 days as this is a busy time of the year and there are several steps in getting it registered. Make sure you have taken the safety test and watched the safety video if you are a new watercraft owner. If you have sold a watercraft, please let us know that as well. New watercrafts to the lake need to go through the water patrol for inspection. Our water patrol will call you to set up an appointment once we have all of the information needed to start your application process.

If you have new non motorized watercrafts, you will need to fill out the application Non-Motorized Application Form. Fill out a form for each one that is new to the lake only. Residents with existing non motorized watercraft, from last year, will already have an application waiting for them in the office. A copy of your declaration page of your HOMEOWNERS INSURANCE will be required in order to get these stickers.

**\$75.00 for Motorized \$20.00 for Non-Motorized**

# STICKER LOCATION FOR BOATS AND TRAILERS

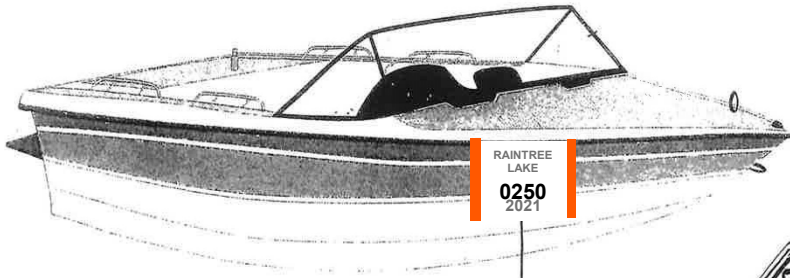

BOAT WITH WINDSHIELD

STICKERS

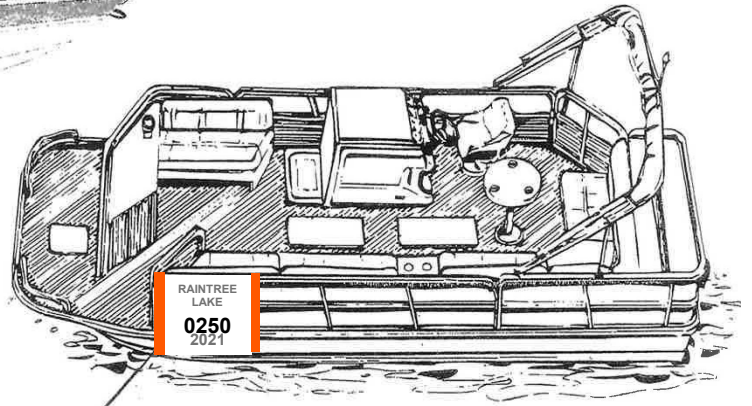

STICKERS

PONTOON

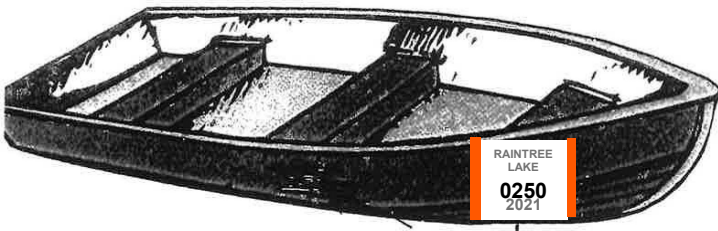

BOAT WITHOUT WINDSHIELD

STICKERS

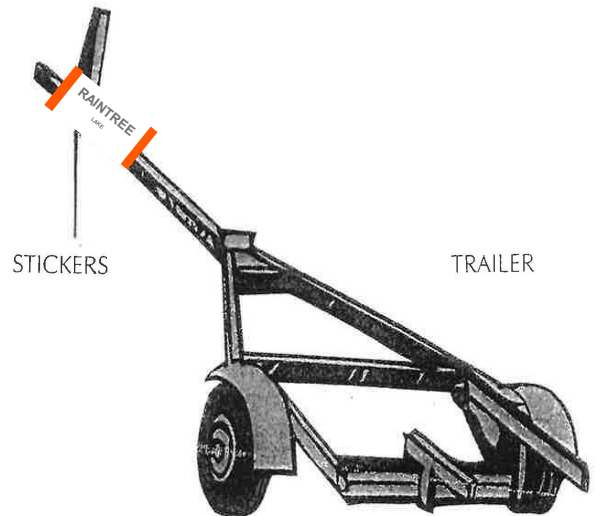

STICKERS

TRAILER

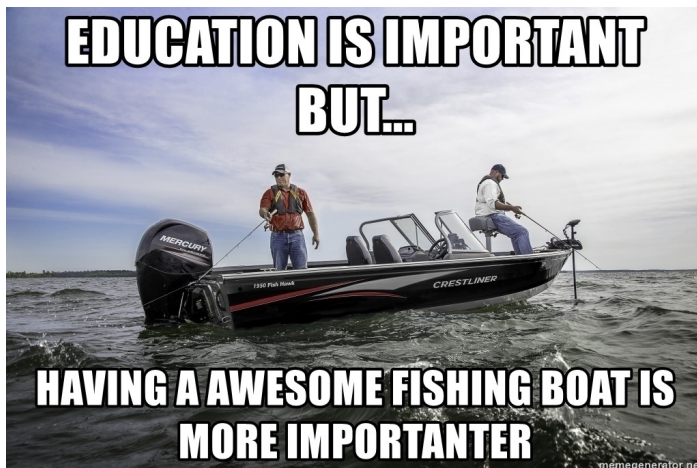

# STICKER LOCATION FOR PERSONAL WATERCRAFT

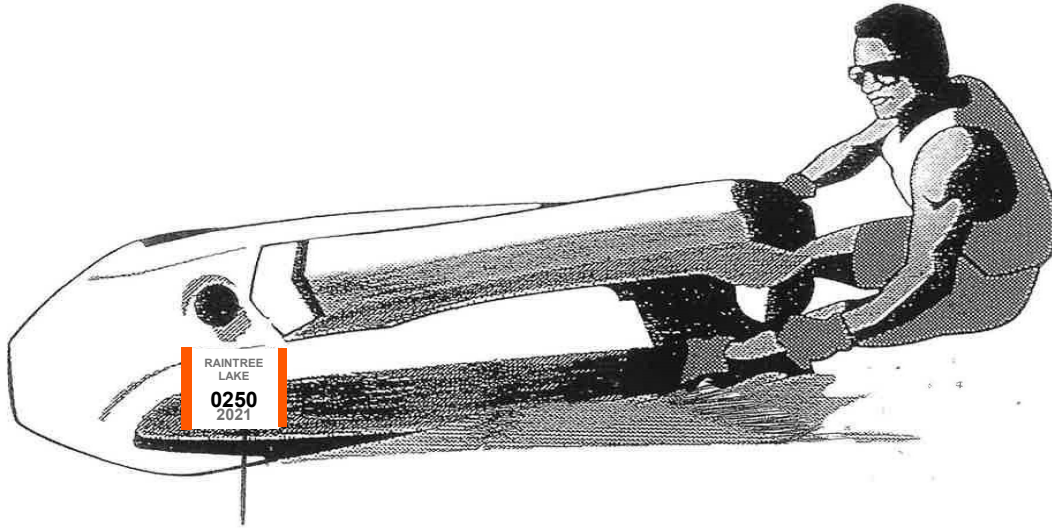

STICKERS

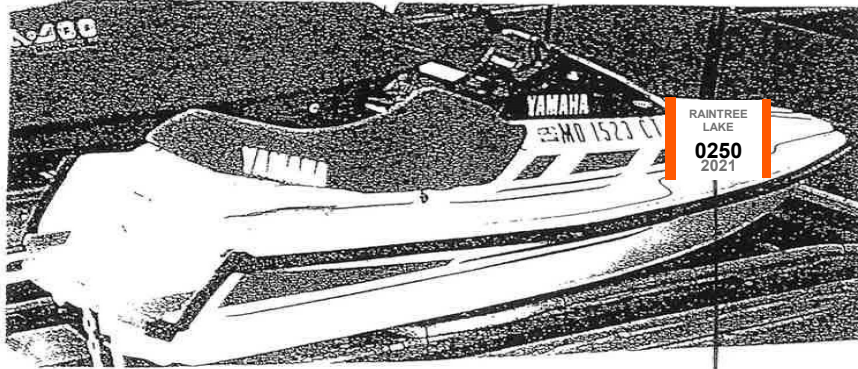

STICKERS

# STICKER LOCATION FOR NON-MOTORIZED



STICKERS



## 2021 FEES

Assessments:	Fee
Class A Single Family Annual	\$550.44
Class A Single Family Quarterly	\$137.61
Class B Multi-Family Annual	\$366.72
Class B Multi-Family Quarterly	\$91.68
Commercial Annual	\$489.84
Commercial Quarterly	\$122.46
Boat Slips:	Fee
Boat Slip Lease (Annual)	\$375.00
Boat Stickers:	Fee
Motorboat	\$75.00
Non-motorized	\$20.00
Clubhouse:	Fee
Full Day Use Friday-Saturday-Sunday (9am - 12am)	\$500.00
Half-Day Use Monday - Thursday (excluding holidays) (Noon-10 pm)	\$200.00
Deposit	\$300.00
Mandatory Cleaning Fee	\$150.00
Duck Pond Activity Center:	Fee
Full Day Use Friday-Saturday-Sunday (9am - 10pm)	\$200.00
Half-Day Use Monday - Thursday (excluding holidays) (4-10pm)	\$75.00
Deposit	\$250.00
Mandatory Cleaning Fee	\$75.00
Pontoon (includes one tank of fuel!!):	Fee
Weekday, Full Day Use (8 am - 9 pm)	\$160.00
Weekday Early Bird Special (Mon-Thu, 8 am-2 pm, non-Holiday)	\$60.00
Weekday Afternoon (3:00 pm - 9:00 pm)	\$125.00
Weekends Full Day Use (8 am - 9 pm)	\$185.00
Weekend Morning (8 am - 2 pm)	\$125.00
Weekend Afternoon (3 pm - 9 pm)	\$125.00
Holiday Full Day Use (8 am - 9 pm)	\$200.00
Holiday Morning (8 am - 2 pm)	\$125.00
Holiday Afternoon (3 pm - 9 pm)	\$125.00
Deposit	\$250.00
Pool:	Fee
Residents	<b>FREE</b>
Guests - First 10 guests per lot	<b>FREE</b>
Guests - Visits after the 10th	\$2.00
Babysitter/Caregiver Pass	\$50.00
Resident ID:	Fee
First card per resident	<b>FREE</b>
Replacement card per resident	\$5.00
Activities:	Fee
Easter Egg Hunt, Summerfest, Visit with Santa, etc.	<b>FREE</b>



# ZEBRA MUSSEL



## Invasive Species

### Quick Stats:

**Size** - up to 1.5 inches in width, but most are about dime-sized

### Identification:

Zebra Mussels are named for their zebra-like striped pattern that goes across the shell, but this marking is not always present. Unlike native mussels, zebra mussels attach to substrates by filaments called byssal threads.

### Habitat:

These mussels prefer lakes and rivers such as the Missouri River and attach to practically any stable thing they can find in these bodies of water, from rocks to boats and even other mussels.

### Reproduction:

Zebra Mussels reach sexual maturity before they are one year old. Once a female finds a suitable spot, she will produce up to one million eggs per year. The free-swimming larvae are carried by the Missouri River's current and the population is dispersed.

### Diet:

Mature Zebra Mussels feed by filtering water through their bodies and extracting the plankton. A Zebra Mussel can filter up to one liter of water per day.

### Reasons for Invasive Status:

Originally from the seas of Eastern Europe and Central Asia, this species was accidentally brought over by cargo ships coming into the Great Lakes from the Black Sea. Zebra Mussels can spread so quickly because not only do they reproduce in huge numbers, but they can also survive multiple days out of water, allowing them to be transported on boats and other equipment.

It is unclear how to stop Zebra Mussels from spreading once they arrive in an ecosystem. Zebra Mussels were found in Missouri in 1991 in the Mississippi River. By 1999 they spread to the Missouri River near Sioux City, Iowa. They have also been found in the lower Meramec River and the Osage River. They are spreading throughout lakes in Missouri too, and have been reported in the Lake of the Ozarks and Bull Shoals Lake.

They cause problems for ecosystems primarily by eating the same food that native fish need to grow, making fish population growth more difficult. Zebra Mussels also cause problems for humans by damaging boat parts and clogging pipes used for water supply. Their sharp shells can litter swimming areas, cutting the feet of beach-goers.

### Sources:

Graham, Bill. (2017). "MDC Confirms Zebra Mussels in Three Jackson County Lakes." Missouri Department of Conservation. Retrieved from <https://mdc.mo.gov/newsroom/mdc-confirms-zebra-mussels-three-jackson-county-lakes>

"Zebra Mussel." United States Geological Survey. Retrieved from <https://nas.er.usgs.gov/queries/factsheet.aspx?speciesID=5>

"Zebra Mussel." Missouri Department of Conservation. Retrieved from [https://mdc.mo.gov/sites/default/files/resources/2010/08/zebra\\_mussels.pdf](https://mdc.mo.gov/sites/default/files/resources/2010/08/zebra_mussels.pdf)

"Zebra Mussel Control." Missouri Department of Conservation. Retrieved from <https://mdc.mo.gov/wildlife/nuisance-problem-species/invasive-species/zebra-mussel-control>



**Zebra Mussels will attach to anything they can find, from rocks to other mussels.**







## Home Improvements May Need Approval!!!!

With spring in full swing, you may be making plans for some exterior maintenance on your home. Please remember that exterior changes may need approval from the Architectural Review Board (ARB). During the outbreak of the coronavirus, the ARB has not been publicly meeting, however, they are working on reviewing applications that have been turned in on an “as needed basis” to assist residents with their projects. ARB applications can be found on our website at [www.rlpoa.com](http://www.rlpoa.com) under “For Residents” > Forms > Architectural Review Forms. Please select the application required for your project. Some applications do require “plot plans,” so contact the office if you do not have one available and we can check to see if we have one on file. **ALL APPLICATIONS HAVE TO BE TURNED INTO THE RAINTREE OFFICE—PLEASE DO NOT EMAIL THEM TO THE ARB DIRECTLY.**

Here are some of the items that have to be approved: Roof Replacement, Exterior Paint (repainting existing color or new color choice), Fences, Pools, Decks/Patios, Retaining Walls, Play Equipment, and Driveways. This is to name a few.

*Failure to receive prior approval will result in a \$200 fine. If you have any questions, contact the office at 816-537-7576.*



STAY  
IN  
THE  
LOOP

Sign up for e-News and stay current on Raintree events with weekly bulletins and instant news alerts on important items of interest such as water quality reports, police alerts, and changes in Raintree activities.

Sign up at: [www.rlpoa.com](http://www.rlpoa.com)

**1,790 members are already signed up!**

**DID YOU KNOW????**

**Current rules and regulations can always be found on the website:**

**[www.rlpoa.com](http://www.rlpoa.com)**

**Then click:**

**Area Information > Rules and Guidelines > 2021 Searchable Directory**



Did you know you can see previous editions of the Shoreline on our Raintree website:

[www.rlpoa.com](http://www.rlpoa.com)

**Check it out!**





## MEMORIAL DAY

It is the **SOLDIER OR VETERAN**, not the preacher,  
who has given us freedom of religion.

It is the **SOLDIER OR VETERAN**, not the reporter,  
who has given us freedom of the press.

It is the **SOLDIER OR VETERAN**, not the poet,  
who has given us freedom of speech.

It is the **SOLDIER OR VETERAN**, not the lawyer,  
who has given us the right to a fair trial.

It is the **SOLDIER OR VETERAN**, not the politician,  
who has given us the right to vote.

It is the **SOLDIER OR VETERAN** who salutes the Flag.

It is the **SOLDIER OR VETERAN** who serves under the Flag.

It is **EVERY AMERICAN** who salutes every Soldier and Veteran  
and thanks him and her for the freedoms we enjoy everyday.

### Leaving the Gate Open at the Boat Ramp is a Violation!!



#### VII. MISCELLANEOUS OPERATING RULES:

22. Boat Ramp Gate: Each resident must close and lock gate after each use to load or unload a boat onto Raintree Lake, provided there is not another resident with current sticker waiting to use the ramp. Failure to close and lock the boat ramp gate is a violation. Approved 7-10-18

The gate at the boat ramp is intended to serve as a reminder that every boater at Raintree is responsible for the health of our lake.

There are two reasons for the gate: trespassers and invasive species control. Trespassing boaters have been relatively minimal, but they cause a fair amount of concern. A locked gate is expected to send a very clear message to would-be trespassers.

The second reason, invasive species control, is a much more significant challenge that could affect all residents. The invasive species of most concern to the Lake Committee and the Board is zebra mussels. Zebra mussels can cause significant damage to boats and structures in the lake as well as injury to swimmers—all of which has the potential to reduce property values in our community.

Zebra mussels reproduce at incredible rates. A single female zebra mussel can reproduce a million eggs each year. Zebra mussels are not visible to the naked eye in their larvae stage. Zebra mussels have been identified a number of locations in Missouri and Kansas. They have not been found in Raintree Lake at this point.

Key points to remember: **CLEAN, DRAIN, DRY, DISPOSE.** Cleaning with water heated to 140°F instantly kills mussels. The Boat/Truck wash next to Casey's in Greenwood is set to a minimum of 140°F and is recommended for use by all boats that have been in infested waters prior to re-entry into Raintree Lake. In addition to cleaning and drying the boat, special attention should be paid to trailers, bilges, live wells, ballast tanks, bait buckets, fat sacks, life jackets, tubes, wakeboards, skis, ropes, wet suits and any other gear that has been in infested waters to ensure that they are thoroughly cleaned and dried as well.

## Raintree Frequently Asked Questions

Q: Why does the office send a letter when I have a Codes Violation or delinquent account rather than calling me or stopping by the house?

A: The Raintree office sends out letters to Residents rather than calling or visiting in person because letters mailed out are also kept on file to document the communication. A phone call or personal visit is not as easy to document. Also, with over 2000 lots, it would be a time-consuming effort to call or visit each time.

Q: I've lived in Raintree for nearly 20 years and have never caused any kind of trouble. But the first time I leave my trash out too long, I receive a letter about it when my neighbor has trash all over his yard and has peeling paint on his house and nothing is ever done.

Q: Our Codes Administrator documents all codes violations and sends out letters. If a resident does not comply, they will receive additional letters and fines will be assessed. Some residents are quick to comply, others are not. In some cases of non-compliance, the matter is eventually turned over to the City.

**Got Potholes??  
Help out your Raintree  
Neighborhood by  
reporting.**



### LS Connect Helps you:

**Get Connected. Report Concerns. Stay Engaged.**

LS Connect keeps you connected to important City of Lee's Summit news and information, and also allows you to easily report some common non-emergency concerns such as potholes, codes violations, streetlight outages, and more. LS Connect is available as a free mobile app, and the reporting feature is also available online at LS Connect.

**Raintree Residents:** This is a great tool to let the city know about the potholes that are on your street! Please help the neighborhood by contacting the city!

## WHO YOU GONNA CALL?



**Frustrated! Don't know who to call? Here are some helpful phone numbers, for some of our every day problems.**

### **Police Non-Emergency: 969-7390**

Graffiti  
Loud music/noise  
Public drinking  
Suspicious solicitor  
Abandoned car  
Illegal dumping  
Illegal fireworks  
Underage drinkers  
Car or home alarm  
Belligerent person

### **Lee's Summit Neighborhood Services 969-1200**

Overflowing trash bins  
Tall grass  
Abandoned appliance  
Foul odor  
Trash in yard  
Abandoned & deteriorating houses

### **Lee's Summit Public Works Dept. 969-1800**

Repair of City streets and sidewalks  
Broken traffic signal  
Flooded street  
Broken street sign  
Clogged storm drains  
Hazardous sidewalk  
Potholes

### **Lee's Summit Snow Desk: 969-1870**

### **Lee's Summit Animal Control 969-1640**

Wild animals  
Dead animals  
Barking dog  
Rats

### **Lee's Summit Water Dept. 969-1900**

Polluting/pouring oil in drain  
Leaking fire hydrant  
Water main break





# RAINTREE RAYS



## Swimmer Registration

April ~ TBD

## Parent Meeting

April ~ TBD

## New Swimmer Evals

May 25, 26, 27 ~ 5-6pm

## Practice Schedule

June 1 - July 16

Monday - Friday

7-8am High School

8-9am Ten & Under

9-10am Eleven-Fourteen

## Team Banquet

July 21st 4-9pm



## 2021

# MEET SCHEDULE

1: June 9 - HOME-vs-Winterset

2: June 16 - Away-vs-New Longview

3: June 23 - Away-vs-Lakewood Cruisers

4: June 30 - Away-vs-Lakewood Lasers

5: July 7 - HOME-vs-Windsboro

6: July 14 - HOME-vs-BentTree

Championships - July 16/17 - Away TBD

(Rain-Outs are typically the Thursday after cancelled meet)

# **RAINTREE TENTATIVE 2021 POOL HOURS:**

**May 24—28: 4:00 pm—8:00 pm**

**Memorial Day Weekend: May 29—31: 10:30 am—9:00 pm**

**Starting June 1:**

**Every day except Thursdays: 10:30 am—9:00 pm**

**Thursdays 10:30 am—8:00 pm**

**(Adult Swim—for those 18 years old and older,  
8:00 pm—10:00pm)**

Watch the Shoreline for special events causing a change in pool hours.

**\*\*\*FLEXIBILITY IS STILL KEY MOVING FORWARD AS DATES/TIMES CAN STILL  
CHANGE ACCORDING TO JACKSON COUNTY HEALTH DEPARTMENT)**



## **Raintree I.D. Troubles?**

Lose your Raintree ID? Dog tear it to shreds?  
Sunscreen smear it into something unrecognizable?  
Whatever shall you do?

No need to fret, the Raintree Office can help!

To replace a ruined card, bring what is left and you  
will receive a replacement at no cost to you! Lost  
cards will be a \$5.00 charge to replace.



## **Babysitter- Caregiver- House Sitter Pass-**

Babysitter passes, Caregiver passes, and House Sitter Passes are available for \$50.00 in the Raintree Office for the 2021 Pool Season. A Raintree homeowner must come to the office to fill out the necessary paperwork before pass will be granted. The office accepts payment of cash or check.

# May

Sun	Mon	Tue	Wed	Thu	Fri	Sat
				29	30	1
				<b>Raintree Spring Garage</b> 		
				<b>Garden Club Fundraiser April 23– May 1</b>		
2  Angler's Tournament 7am-12pm	3 Cards 1:00 pm at DPAC  Lake Committee 7pm at Clubhouse	4  Ladies Bridge 9:15am & Men's Club 1:30pm both at DPAC	5 ARB DEADLINE  Cinco de Mayo  	6 Mahjong 1pm DPAC	7 ARB Meets	8
9 	10	11 RLPOA Board Mtg.  Ladies Bridge 9:15am & Men's Club 1:30pm both at DPAC	12 ARB DEADLINE  Ladies Bunco 10 am at DPAC  Canasta 1-4 pm at DPAC	13 Mahjong 1pm DPAC	14 ARB Meets	15 Shoreline Deadline
16	17 Bee Keepers 9 am—4pm at DPAC	18 Ladies Bridge 9:15am & Men's Club 1:30pm both at DPAC	19 ARB DEADLINE Fountain's Activities 1:00 pm at DPAC  Garden Club Meeting 7pm at DPAC	20 Mahjong 1pm DPAC	21 ARB Meets	22 Lake Clean up 9am-12pm  
23	24	25	26	27	28	29
<b>Pool Opens 4-8 pm Masks &amp; Social Distancing Required</b>						
30	Fountain's Bunco 1-3 pm at DPAC  31 Memorial Day/ Fishing Derby  	RLPOA Work Session  Ladies Bridge 9:15am & Men's Club 1:30pm both at DPAC	ARB DEADLINE Canasta 1-4 pm at DPAC Wine Club 7pm at DPAC	Mahjong 1pm DPAC	ARB Meets	



# LAKE CLEAN-UP

Our annual Lake Clean-Up is planned as a family activity to clean up our shoreline and neighborhood.

Saturday, May 22, 2021

9:00 A.M. – Noon

Make this a family event! Trash bags and cold bottled water will be available. Exciting gift certificates available for all ages! Mom and Dad will want to join in the activity!

I would love to have someone assist this year and take over this event as Coordinator for 2022. If you are interested email me at [clyon@rlpoa.com](mailto:clyon@rlpoa.com). Thanks!

## Checklist for Safe Boating

### Pre-Departure

- 1) Check weather report
- 2) Always tell someone, if you will be boating alone.
- 3) Identify non-swimmers in your party. Supply non-swimmers with life-jackets that fit and that they will wear while on the water. Boat should be equipped with a life jacket per person.
- 4) Identify the location of safety items for your crew.
  - \* Life jackets readily accessible
  - \* Throwable flotation immediately accessible
  - \* Horn or sound-producing device
  - \* Fire extinguishers
  - \* Check navigational lights if you will be out past dusk.
  - \* Red/orange flag
  - \* Two oars-it's difficult to get to shore with one
- 5) Identify incremental recommended gear.
  - \* Radio
  - \* Cell phone
  - \* Anchor with rope
  - \* Towline, approximately 75' X 1/2"
- 6) Before engine is started:
  - \* If gasoline inboard: run blower for a least four minutes.
  - \* Check lubricating oil
  - \* Check fuel level
  - \* Attach kill switch lanyard

### While on the water

- 1) Drink responsibly
- 2) Be weather aware
- 3) Know where to anchor if severe weather blows in.
- 4) Monitor fuel consumption

### When you return to the dock

- 1) Moor boat correctly with bow, stern, spring lines and fenders.
- 2) Always On:
  - automatic bilge pump
  - alarms
  - battery charge (inverter may need to be turned off)
- 3) Non-essentials, turn off:
  - running lights
  - stereo
- 4) Secure or remove valuables from boat
- 5) If you informed someone you were going out alone, let them know you made it home!



### WANT TO PUT A BOAT ON RAIN TREE LAKE?

Learn how on the Raintree website at [www.rlpoa.com](http://www.rlpoa.com)

Look under < Committees < Lake Committee  
< Watercraft Verification Process for New Boats



Know where Common Ground is!  
Don't Trespass!!





## Less Lawn Care Means More Lake Protection



If you love our lake, we need to change our idea about what looks good! That short, weed-free lawn that many of us admire can actually hurt our lake because it: 1) Takes more chemicals to keep it green. 2) Does not provide good habitat for wildlife or aquatic life.

Excess fertilizers and pesticides can go into the lake. The resulting algae bloom and floating, dead fish remind us that using less chemicals is better. Excessive algae decreases recreational value, odors develop, impacts dissolved oxygen and reduces water clarity. If you must use fertilizer, have a soil test done first and follow the recommendations. Try to use phosphorus-free fertilizers, slow release nitrogen and leave a buffer area near your lake where no chemicals are used. When shopping for fertilizer look at the numbers on the bags. Example 12-6-6 is Phosphorus-Nitrogen-Potassium.

Organic fertilization is a healthy alternative to synthetic fertilization. It does not necessarily entail a manure spreader and the maintenance of a compost heap in these modern times. To the contrary, today's organic fertilizers are easy to use and without the mess and odor long associated with antiquated organic methods. The advantages are: 1) Safe for humans and pets 2) Non-toxic and environmentally friendly 3) More economical than traditional fertilizer 4) Builds soil fertility for long-term results 5) Promotes healthier, more resilient turf 6) Greatly reduces watering costs 7) Non-burning and easy to apply. Recommendations to start with organics are: 1<sup>st</sup> application in the early spring is a 3-1-5, 2<sup>nd</sup> application mid-spring is 9-0-0, 3<sup>rd</sup> application early summer is 3-1-5, 4<sup>th</sup> application in early fall is 3-1-5 and the 5<sup>th</sup> application early October is 9-0-0.

Grass clippings are high in nutrients so you want to keep them **OUT OF OUR LAKE**. Bag grass clippings and fall leaves or use a mulching mower or both. **REMEMBER ALL STREET STORM DRAINS LEAD TO OUR LAKE!**

# SPRING SCATTERGORIES

## F L O W E R

A Spring Flower						
A Spring Break Destination						
A Garden Plant						
A Baby Animal						
A Spring Activity						
Best thing about Springtime						
A game that you Play						

Fill in each category above with an answer that begins with the letter in bold. Example: Spring flower that begins with the letter F could be Foxglove. Continue to answer for each category beginning with the letter F, L, O, W, E, R.

# Keep Dues Up-to-Date!



Second quarter billing for 2021 was mailed out in March and will be due by June 30th.

For your convenience, there are **FOUR WAYS TO PAY** your Raintree dues:

◆ **Direct ACH Debit**— Stop by with a voided check and we'll help you get set up!

◆ **Drop it off!** Pay in the office with check or cash (same address as above.) Also, there is a drop box available by the office door, in case you want to drop something off when office is closed.

◆ **Mail it in!** (825 SW Raintree Drive)

◆ **Online at RLPOA.com**—pay from the comfort of your home (fees apply). **Show your receipt in the office if you need immediate proof of your transaction.**

Raintree Lake POA is pleased to offer electronic ACH Debit to you, our residents. ACH direct debit payments provide an alternative and easy way to pay your dues, affording you the following advantages:

- ◆ Certainty of on time delivery
- ◆ Establishment of excellent payment and credit records
- ◆ Eliminating paper check handling and check depositing
- ◆ Being part of "Going Green" by reducing paper

How do I get started? Complete and sign the ACH Enrollment Form on the next page. Once the form is completed bring the form and a copy of a Voided Check into the office to set up.

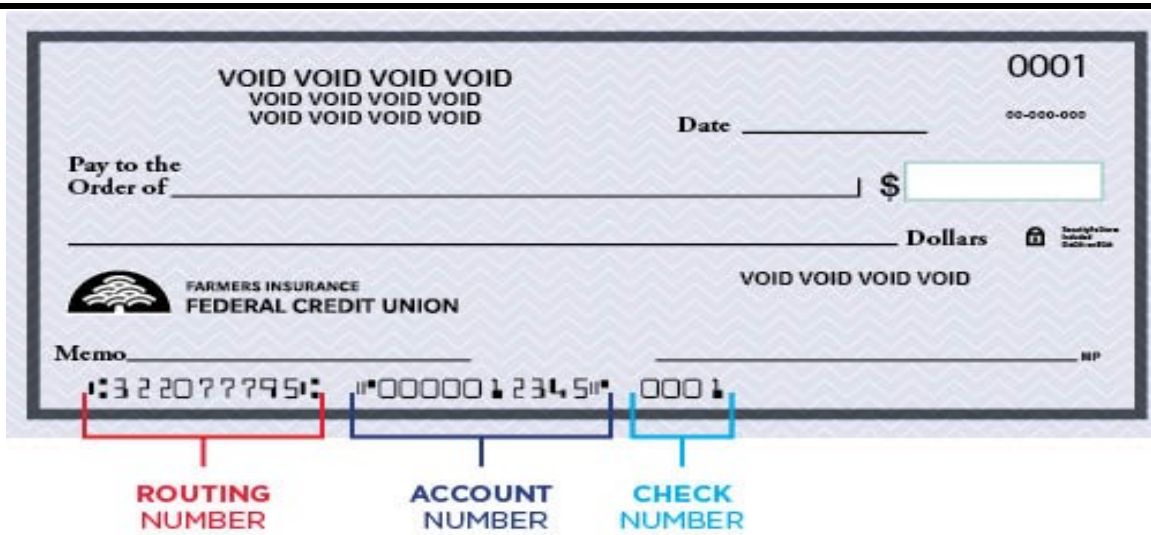

# Raintree Lake Property Owners Association

## AUTHORIZATION AGREEMENT DIRECT PAYMENTS (ACH DEBITS)

I (we) hereby authorize Raintree Lake Property Owners Association, hereinafter called RLPOA, to debit entries to my (our) account indicated below and the Financial Institution named below, hereinafter called FINANCIAL INSTITUTION, to debit same to such account. I (we) acknowledge the origination of ACH transactions to my (our) account must comply with the provisions of U. S. law.

\_\_\_\_\_  
(Financial Institution Name) (Branch)

\_\_\_\_\_  
(Address) (City-State) (Zip)

\_\_\_\_\_  
(Routing/Transit Number) (Account Number) Type of Acct: \_\_\_ Checking \_\_\_ Savings

Please check the appropriate withdraw method.

- Quarterly  15th of the month  Monthly  15th of the month  
 28th of the month  28th of the month

1st  2nd  3rd month of quarter

This authority is to remain in full force and effect until RLPOA has received written notification from me (or either of us) of its termination in such time and manner as to afford RLPOA and FINANCIAL INSTITUTION a reasonable opportunity to act on it.

\_\_\_\_\_  
(print individual name) (print individual name)

\_\_\_\_\_  
(print address/lot number) (print address/lot number)

\_\_\_\_\_  
(Signature) (Signature)

\_\_\_\_\_  
(Date)

**PLEASE ATTACH COPY OF VOIDED CHECK TO THIS FORM**

*(Customer retains second copy)*

# ***New Residents Welcome to the Neighborhood!***

Peter & Margaret Fletcher  
1000 SW Drake Circle

Brad & Breanne Lightfoot  
4051 SW Leeward Drive

Erika Dahlgren  
3916 SW Linden Circle

William Fair  
313 SW Seagull

Greg & Morgan Shaw  
4005 SW Hidden Cove Drive

Timothy Melia  
3824 SW Harbor Drive

Benjamin & Donna Witters  
316 SW Green Teal



## **Spring/Summer Office Hours**

**Monday - Friday**  
9 am - 5 pm

**Saturday**  
9 am - 1 pm

825 SW Raintree Dr.  
LSMO 64082

[office@rlpoa.com](mailto:office@rlpoa.com)

**General Manager:**  
Rachelle Vandiver  
[manager@rlpoa.com](mailto:manager@rlpoa.com)

Office: 537-7576 Fax: 537-5621



## **Welcome Baskets: An Opportunity for Advertisers**

Are you a resident who would like to advertise the products or services offered by your company? Consider adding an item to our Welcome Basket that would contain your logo or information regarding your business or product. There is no cost to you to add something to the basket.

New residents to Raintree typically receive a Welcome Basket when they come visit the office for the first time. The Welcome Baskets contain things like koozies, cups, key chains, toothbrushes, pens, coupons, lotion, hats or visors, magnets, ads for local businesses and at one point we even had bar-b-que sauce! You never know what might be included!

Would you like to add something to our Welcome Baskets to advertise your business? Bring your item(s) by the office during office hours.

## **ROAD CLOSURE!**

MoDOT is planning for bridge work to take place in the Spring of 2021. MO 291 will be closed in order to allow for the work. It is a bridge deck replacement, and does include a full closure of MO 291 during the work. The closure is expected to last 40-50 days, and hopes to be open to traffic by June 19<sup>th</sup>. The official detour will utilize MO 150, MO 7, and MO 58 to route traffic around the work zone.





## My Grandchild

My grandchild when you have older grown  
I'll take you to a lake I've known  
At midnight, noontime, dusk or dawn.  
I want to show you where I've gone  
To find my freedom....  
And I want to be in a boat with  
You and have you see  
And learn from me, oh grandchild of mine,  
How to cast a fishing line.

For I've been young and too well I know  
The rocky road your feet must go.  
But I know, too, a path that clings!  
To a wooded hill where the bluebird sings.  
Where dogwood grows, and oak and pine,  
And all I ask, oh grandchild of mine,  
Is to row that boat for you someday  
Along the shore where the willows sway  
To be with you when first you feel  
A leaping fish unwind your reel.

I want you to sleep, as I have slept  
Beneath the heavens' reach, star swept.  
I want the dawn's first gold betide  
To waken something deep inside.  
I want you, my child, to learn to take  
Your troubles to a shining lake  
And lose them there.

*Anonymous*

# Teens for Hire

Call Office to update: 537-7576

Name	Age	Services	Telephone
Tiarnyn	16 1/2	Dog sitting or walking, babysitting, mowing	816-977-6052 or 913-271-2918
Kylie	16	Dog sitting, Dog walking, Babysitting, House sitting	714-269-4089
Ella	16	Responsible Mother's Helper - Fun & Energetic Babysitter! Raymore Parks & Rec CPR Certified	(816) 882-3193
Kolby	14	Dog walking, Dog sitting, House sitting, Babysitting	562-676-3816
Gabby	16	Certified Babysitter. CPR Trained. Dog Walking	(816) 743-1955
Jada	17	Babysitting (Certified Babysitter & CPR Training), Dog Walking and Dog Sitting	816-898-2249
Kennedy	16	Babysitting	816-489-8776
Riley	15	Nanny, Dog Walker, Housesitting	816-560-2278
Christian	13 1/2	Pet sitting, Snow removal, Leaf/limb removal	816-927-5290
Ainsleigh	14	Pet sitting, Dog walking, Exotic pets, Babysitting for older kids (no infants or very young toddlers.) Has taken CPR and babysitting boot camp with LSPR.	312-953-5821
Sam	15	Mowing, snow shoveling	816-207-9019
Isabella	13	Experienced house and pet sitting	816-377-1177
Kendall	16	Babysitting	816-663-0034
Brooke	15	Babysitting	816-352-6500
Mark	16	Car and Boat detailing. 3 years experience.	913-515-6949
Grant	14	Sharpens knives	913-515-6949
Libby	12	Pet sitting—lots of experience!	816-609-8577
Molly	17	Babysitting and pet sitting	816-207-8886
Angelina	16	Certified babysitter / dog sitter—References Available	816-503-1241



# ***Raintree Lake Annual Memorial Day Fishing Derby***

***Monday, May 31, 2021***

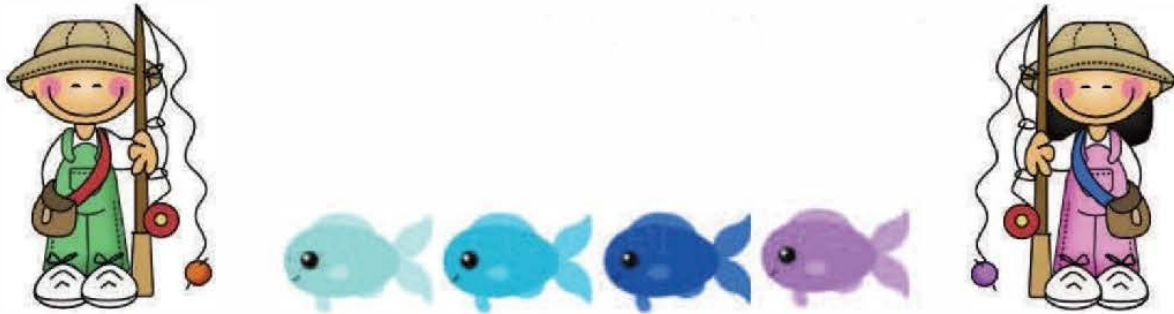

Yeah...this year's Fishing Derby is on!!! ALL Raintree kids (ages 2-18) and their families are welcome to attend the 2021 Raintree Lake Memorial Day Fishing Derby. The Derby will be held at the **Duck Pond** on **Monday, May 31** (Memorial Day). Registration begins at **8:00am** and the fishing will kick off promptly at **9:00am** and end at **10:30am**. Prizes in each age category, snacks, and drinks for the families will be provided. We hope to see you there! Award ceremony will immediately follow the event.

It is hard to know what health orders will be in place on May 31, but in order to hold this event everyone will need to adhere to whatever those orders are.

Buckets will be available for the fish that are caught, before they are judged and released. We will also have a limited supply of rods, reels & bait for any child who might need them.

To help make this event a success for our kids, additional volunteers in the following areas are needed:

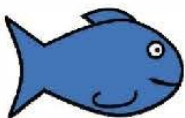

- Registration
- Set up and break down of event
- Judges to man the perimeter of the pond

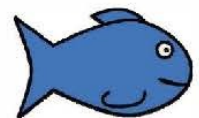

***For more information or to volunteer your time, contact  
Brenda Zeller (816-617-4466 or bzeller11@gmail.com)***

# The Origin of Mother's Day: 5 Surprising Facts About the Holiday

## 1. Mother's Day officially began as a tribute to one woman.

Anna Reeves Jarvis is most often credited with founding Mother's Day. After her mother Ann died on May 9, 1905, Jarvis set out to create a day that would honor her and moms as a group. She began the movement in West Virginia, which prides itself on hosting the first official Mother's Day celebration three years later at Andrews Methodist Episcopal Church, according to CNN. In 1914, President Woodrow Wilson signed a bill recognizing Jarvis' idea as a national holiday to be celebrated each second Sunday in May.

## 2. But before that, Mother's Day started as an anti-war movement.

Although Jarvis is widely credited as the holiday's founder, others had floated the idea earlier — with a different agenda in mind, according to *National Geographic*. The poet and author Julia Ward Howe had aimed to promote a Mothers' Peace Day decades before. For her and the antiwar activists who agreed with her position — including Jarvis' own mother — the idea of Mother's Day should spread unity across the globe in the wake of so much trauma following the Civil War in America and Franco-Prussian War in Europe.

"Howe called for women to gather once a year in parlors, churches, or social halls, to listen to sermons, present essays, sing hymns or pray if they wished — all in the name of promoting peace," West Virginia Wesleyan College historian Katharine Antolini noted, as cited by *National Geographic*.

These early attempts to create a cohesive peace-focused Mother's Day eventually receded when the other concept took hold.

## 3. Mother's Day is a \$25 billion commercial holiday.

These days, Mother's Day is a \$25 billion holiday in America, with those who celebrate spending about \$200 on mom, according to National Retail Federation data published in 2019.

More people buy flowers for Mother's Day than any other time of year except during the Christmas and Hanukkah season. Gift givers spend more than \$5 billion on jewelry alone, and nearly another \$5 billion on that special outing. Then there's \$843 million on cards, and \$2.6 billion each on flowers and gift certificates, according to the data.

## 4. Jarvis died regretting her idea for this very reason.

Commercialism is the exact opposite of what Jarvis would have wanted: In her lifetime, she went after florists' aggressive marketing, eventually facing arrests for public disturbances, according to *CNN*. She also railed against first Lady Eleanor Roosevelt for interpreting Mother's Day inclusively as a way to promote the wellbeing of women and children at large. She didn't even believe in organizations using the occasion as a way to raise funds for charity; she didn't trust the purity of their efforts and saw them as profiteering off the holiday.

"To have Mother's Day the burdensome, wasteful, expensive gift day that Christmas and other special days have become, is not our pleasure," she said in 1920, according to *Nat Geo*. "If the American people are not willing to protect Mother's Day from the hordes of money schemers that would overwhelm it with their schemes, then we shall cease having a Mother's Day — and we know how."

Jarvis herself never profited from her idea. In 1948, at the age of 84, she died penniless — having used all her money to fight the holiday's commercialization — in a sanitarium.

## 5. The white carnation is the official Mother's Day flower.

The white carnation became the official flower of the holiday shortly after Jarvis' own mother died. On May 10, 1908 — three years after that loss — Jarvis sent 500 white carnations to Andrews Methodist Episcopal Church in her mother's honor for that first Mother's Day celebration, according to *Time*.

Jarvis compared that flower's shape and life cycle to a mother's love. "The carnation does not drop its petals, but hugs them to its heart as it dies, and so too, mothers hug their children to their hearts, their mother love never dying," she said in a 1927 interview, cited in *Nat Geo*.

So if you're buying flowers for mom this year, consider the white carnation — but also pause to consider the holiday's uncommercial origins. After all, it's not about flowers, or cards, or gift cards, or jewelry — it's all about love.

<https://www.goodhousekeeping.com/holidays/mothers-day/g32129906/mothers-day-origin/>







# Mother's Day

Second Sunday of May

G	T	O	A	N	O	I	T	A	I	C	E	R	P	P	A
D	E	T	O	V	E	D	C	W	G	A	E	R	A	H	S
E	N	E	A	M	L	O	A	E	U	S	T	F	I	G	T
T	D	A	O	O	M	R	N	I	I	O	C	W	I	S	E
H	E	M	V	F	M	O	S	I	D	H	O	S	U	T	P
E	R	E	O	S	H	B	R	E	A	K	F	A	S	T	R
B	E	R	R	P	R	T	I	R	N	O	U	P	M	E	O
E	T	Y	E	G	R	E	M	A	C	H	E	O	L	T	T
S	E	L	R	C	N	I	W	M	E	R	E	U	M	R	E
T	E	E	A	E	N	I	A	O	F	O	F	S	O	E	C
T	N	N	R	G	L	T	V	U	L	I	T	E	T	T	T
E	D	A	R	U	E	E	M	I	T	F	O	S	H	H	I
Y	E	A	V	R	T	E	W	U	G	E	Y	S	E	G	V
E	E	Y	N	R	I	R	A	E	W	R	G	I	R	U	E
M	O	A	E	O	T	E	U	E	J	U	O	K	C	A	T
J	L	A	G	R	B	I	I	N	H	U	O	F	E	L	N

APPRECIATION  
BEAUTIFUL  
BREAKFAST  
CANDY  
CHARMING  
COMFORT  
DEVOTED  
FLOWERS  
FORGIVING  
GIFTS

GUIDANCE  
HUGS  
JEWELRY  
JOY  
KISSES  
LAUGHTER  
LOVE  
MATERNAL  
MOM  
MOTHER

NURTURE  
PERFUME  
PROTECTIVE  
SHARE  
TELEPHONE  
TENDER  
THE BEST  
WARM  
WISE



**Schedule your project and outdoor living space needs today to secure an early install for Spring!!!**

## RAINTREE LAKE PROJECTS

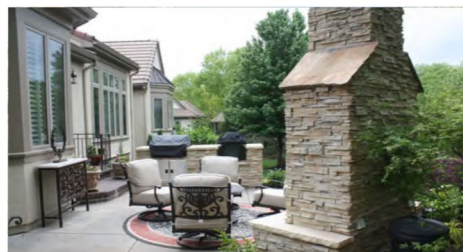

**Design & Build • Patios • Outdoor Kitchens • Seating Walls & Columns  
Fire Pits & Fireplaces • Outdoor Lighting • Landscaping**

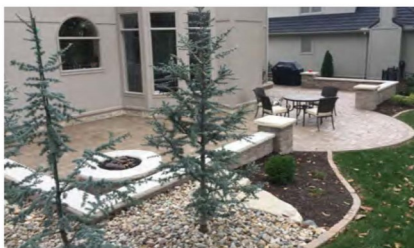

**Call Today: 816-985-9855 FREE ESTIMATES RESIDENT OWNER**



**RENEE AMEY**  
TEAM

**816.213.3421**

[www.LeesSummitLakeHomes.com](http://www.LeesSummitLakeHomes.com)



**3811 SW Ward Road - Raintree - SOLD! \$525,000**



**412 SW Seaside Sparrow Dr - Raintree - FOR SALE \$525,000**



**4828 Leafwing Dr - Raintree - SOLD! \$400,000**



**5127 Sandpiper Dr - Raintree- SOLD! - \$442,900**



**4481 SW Raintree Shore Drive - Raintree SOLD! \$485,000**



**912 SW Drake Drive. - Raintree. SOLD! \$500,000**

Summer is upon us and the market is Hot! Interest rates are still very low and we are experiencing strong demand from buyers for more homes to consider purchasing at Raintree Lake. There could not be a better time to put your home on the market if you are considering moving. Eager Lake Enthusiast Buyers want to enjoy the lifestyle at Raintree Lake! We want to speak with you regarding your next move and/or assistance in selling your home. We look forward to putting more SOLD signs at our #1 selling Lake Community-Raintree Lake!

Visit: [LeesSummitLakeHomes.com](http://LeesSummitLakeHomes.com), the best source for buyers looking for newly listed Lake Homes.  
Renee Amey 816.213.3421 Brenda Durham -Raintree Resident 795.2595/office, Lindsy Davis, Erin Slocum, Chad Davis

**Renee Amey TEAM - RE/MAX® Elite**  
4243 Lakewood Way - Lee's Summit, MO 64064 - 816.795.2595 office



**Appletree Academy "Where Learning Is Fun!"**  
 Successfully preparing preschoolers for kindergarten since 1994



**APPLETREE ACADEMY PRESCHOOL 2020-21**  
 Mrs. West Tue/Thu/Fri Pre-K Class

Sitting L-R: Lucas Patrick, Owen Dobson, Audriana Hill, Elena Perez, Kenady Rincon, Layla Haden  
 Standing L-R: Marlow Twillegar, Cylas Mammoliti, Claire Svehla, Emerson Dearborn, Norah Bennett

**AppletreeAcademy.biz 816-863-5283 AppletreeAcademy01@gmail.com**



**Scentsy**  
 INDEPENDENT CONSULTANT

•••  •••

**Tracy & Joe Damario**  
*SuperStar Directors*

**816-213-8103**  
 WicklessInfo@gmail.com  
 WicklessInfo.com



**DOOR SYSTEMS**

**Make Mom's Day With A Beautiful New Doorway!**

**10% OFF**  
 All Sales & Services!  
 Raintree Lake  
 Mention Code Rain10

- Entry & patio doors
- Energy efficient windows
- Security & storm doors
- Door & window repair and service
- Overhead garage doors & openers

**(816) 744-8044 | 507 SW Lea Dr. Lee's Summit, MO**  
 www.DoorSystemsInc.com Monday - Friday: 8am - 4:30pm  
 Call Today Or Visit Our Showroom! Saturday: 8am - 12pm

FULLY INSURED  
 FREE ESTIMATES  
 WORKMAN'S COMP



**PROFESSIONAL REASONABLE SINCE 1978**

*Rick LaCombe's*  
**TREE SERVICE**  
 Complete Tree Service  
 Trimming and Removal of Trees and Shrubs  
 Firewood • Stump Removal • Snow Removal

**(816) 761-3639**

**BBB MEMBER**

**ROYAL**  
Home Improvements LLC  
816.844.2500

Windows • Siding • Decks • Wood Rot • Painting  
Your home town team for all your home improvement needs



Local Family owned business with 30 years experience Fully Licensed and Insured



1RoyalHomeImprovementsLLC.com

*The Price Is Right Tree Care*

Nathan Wolfe - Owner  
Office: (816) 765-1993  
Cell: (816) 564-1713



Trimming & Pruning • Tree Removal & Stump Grinding  
Lifting & Shaping • Bush & Shrub Trimming  
24 Hour Emergency Services • Fully Insured  
Fire Wood Available • Quality Workmanship & Cleanup  
**FREE ESTIMATES**

www.thepriceisrighttreecare.com

Raintree resident since 2009

**SELF-STORAGE**

**(816) 537-7750**

greenwoodbusinessplaza@gmail.com



\*\*\*NEW 10' X 20' UNITS\*\*\* AT \$125/MO



**Don't move. Instead, improve.**

Remodel, rebuild and renew with Four Sons Construction.  
We specialize in kitchen, basement and bathroom renovation.



We're a third-generation family business with deep roots in the Lee's Summit area. Our reputation lives in your home, so we don't cut corners. We're committed to superior construction, even if it takes a little more time.

816.537.3210

www.foursonscontractors.com



**GRADE - A**



Trimming  
Clean Outs  
Removals



Snow Removal  
Shrubbery  
Stump Grinding

**Tree Care**

There's "No Worry" with Grade-A!

Landscape Division (816)214-6255

Brian West

www.gradeatree.com

816.441.2022

brianwest@gradeatree.com

(816)942-1822



**Creekside Greenhouse**

Annuals-Perennials-Succulents-Vegetables  
Herbs-Tropicals-Shrubs-Garden Decor and more

800 E. Walnut (58 & J Hwys)

Raymore, MO 64083

816-322-7333

www.creekside-market.com

Hours Mon-Fri 9am-5pm

Sat & Sun 9am-3pm



**FINEST DETAILING**

KANSAS CITY'S FINEST MOBILE DETAILING

816.807.8221



David Watzlawick

OWNER/OPERATOR



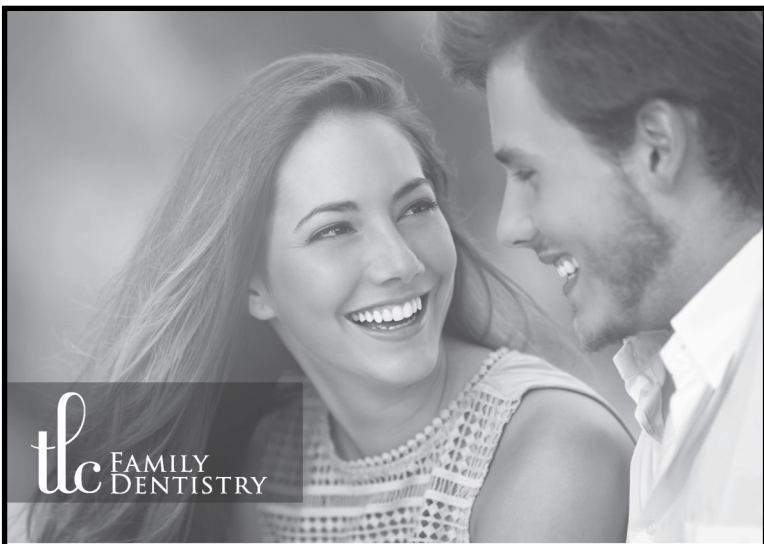

**tlc** FAMILY DENTISTRY

proudly serving patients dental needs in the area for over **35 years**

Call Today For An Appointment  
**816.537.6161**

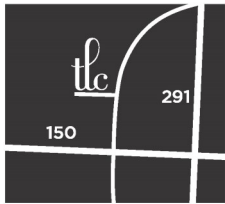

**TLC FAMILY DENTISTRY**  
JAMIE L. THURMAN-TAYLOR, DDS  
3568 SW Market Street  
Lee's Summit, Missouri 64082  
tlcfamilydentistry.com

Conveniently located at the Intersection of Highway 291 and 150, across from QuickTrip



**kw** PLATINUM PARTNERS  
KELLERWILLIAMS REALTY



**SHAWN SUNDEEN**  
REALTOR® and MILITARY VETERAN

Cell: (214) 971-1062

Office: (816) 525-7000

shawn.sundeen@gmail.com

<https://shawn-sundeen.kw.com>

Each Office is Independently Owned and Operated



**SUMMIT**  
Outdoor Designs

[www.SummitOutdoorDesigns.com](http://www.SummitOutdoorDesigns.com)

(816) 524-8565

Call for a **FREE** estimate today!



Follow us on social media!

Providing our customers with the entire Outdoor Living Space!

- Custom Decks
- Patios
- Pergolas
- Privacy Screens
- Fences
- Hardscaping
- Landscaping
- Integrated Lighting
- Power-washing
- Staining

Get your project done now so you can enjoy all summer!

Raintree Resident Owned & Operated

**BUY 1 GET 1 FREE!**

EQUAL OR LESSER VALUE  
NOT VALID ON SPECILITY COMBINATIONS  
MUST PRESENT COUPON AT TIME OF PURCHASE

Valid May 1 - May 31, 2021

**BUY 1 GET 1 FREE!**

EQUAL OR LESSER VALUE  
NOT VALID ON SPECILITY COMBINATIONS  
MUST PRESENT COUPON AT TIME OF PURCHASE

Valid May 1 - May 31, 2021

**NOW OPEN**

LOCATED AT MEINERS MARKET ON 150  
1299 SW ARBORWALK BLVD, LEE'S SUMMIT, MO 64082



KEEP UP TO DATE ON OUR SOCIAL MEDIA FOR THE LATEST NEWS!



@OhanasShaveIce



@OhanasShaveIceKC



OhanasShaveIce.com

BE SURE TO ASK ABOUT OUR **CUSTOMER LOYALTY PROGRAM** AND CHECK OUT OUR NEW FLAVOR SPECIALS COMING EACH WEEK THIS SUMMER!

## BOAT COVERS & SEATS UPHOLSTERED



**CALL ANNA @ 816-519-8707  
TO GET YOUR BOAT SEATS  
REUPHOLSTERED THIS WINTER!**

**CUSTOM BOAT COVERS  
TO FIT YOUR SPECIFIC BOAT!**

OUR TEAM WILL TAKE YOUR OLD UPHOLSTERY AND USE HIGH -QUALITY MARINE VINYL AND THREAD TO CREATE NEW UPHOLSTERY, USING YOUR COLOR CHOICES.

EMAIL; [anna@johnsmarineservice.com](mailto:anna@johnsmarineservice.com)

ADDITIONAL SERVICES;

PWC SEATS AND COVERS ,  
INDIVIDUAL SEAT COVERS.

## CLASSIFIEDS

**Job Wanted:** Cleaning houses, backyards and anything you might need cleaned is my specialty! Please call Kortney's Cleaning Services.  
712-569-7866

**Wanted:** Looking to trade in or sell your old car? Why not donate it to the National Kidney Foundation and gain a tax deduction. The NKF will accept your vehicle, pick it up and turn it into funds for programs and services. For more information, call (913) 262-1551 or (800) 488-2277.

**Wanted:** Lakefront Raintree home with two or more bedrooms on main level. Already living in Raintree and wanting to move in the next few years. Call or text Mark at 816-304-0576.

**Wanted:** Boat slip to sublease for 2021. Our family has been Raintree residents for 10 years and are still on the waiting list for a slip. We would love to sublease any slip for next year. Please call/text Matt at 913-938-4420 or email me at [mkoroch@gmail.com](mailto:mkoroch@gmail.com) Thank you!

**Wanted:** Boat Slip to sublease for 2021. I have 4 children and usually the only adult on board. A slip anywhere on the lake would be such a blessing. Please call or text Nicole at (913) 638-6657.

**Wanted:** SUBLEASE YOUR BOAT SLIP for 1-5 years. Prepay you all \$\$\$ today. You pay HOA when due! Call for details! EJ (913-220-7317) Angela (816-456-8477).

**Wanted: Sublease** For summer 2021! Please call Jacob 816-694-1556.

**Wanted:** We would love to be foster parents to your boat slip! We have 3 active boys and they love the water. Any location is fine! We will care for your boat slip like it was our own. Please call Jason or Molly 816-215-8721.

**Interested in borrowing a pontoon trailer:** Occasional use, once or twice per year. I have a 20' pontoon with two logs. Happy to pay something to contribute to trailer maintenance. Please call Jim at (816) 550-4510.

**For Sale:** 2 Lift Chairs. Brown Used 2 months. \$375 each / 2019 Lexus 350 ES. 17,000 miles Dark navy. Perfect cond. \$37,500. / 2018 Rave Hybrid AWD. 25,000 miles Turquoise. New tires thanks to nails on Raintree Blvd. Like new. \$24,000. Call Fred at 913-515-3941.

# YEAR ROUND YARDWASTE PICKUP!



**CONSTABLE  
SANITATION**

**Sign up  
By calling**

**816.204.1192**

**Constablesanitation.com**

**2021-2022  
RAINTREE  
BOARD OF DIRECTORS:**

**Officers:**

**President: Daniel Merrick  
Vice President: Charlie Burke  
Secretary: David York  
Treasurer: Marsha Powell**

**Board Members:**

**Mike Conway, Tony Jose, Cindy Lyon,  
Kevin Smith and Shawn Sundeen**

**Board meetings are on the second  
Tuesday and Work Sessions are on the  
fourth Tuesday of each  
month at 7:00pm at the Clubhouse.**

**Raintree Staff:**

**General Manager:  
Rachelle Vandiver (537-7576)  
manager@rlpoa.com**

**Assistant General Manager:  
Josh Cresswell (537-7576)  
jcresswell@rlpoa.com**

**Horticulturist/Grounds Manager:  
Tara Rew (537-7576)**

**Water Patrol:  
Mark Soulia (520-3893)**

**Codes Compliance Officer:  
Tim Miller (537-7576)**

**Administrative Assistants:  
Margie Brumble  
Melissa Drinnen  
Debbie Hanss  
Tracy Robertson  
(537-7576)  
office@rlpoa.com**

**Raintree Committee  
Chairpersons:**

**ARB:** Tom Atkins  
**Appeals:** Roland Thibault  
**Common Ground:** Kathy Goldman  
**Lake:** Tim Hamilton & Bob Burasco  
**Pool:** Martha Dooley  
**Activities:** Tonya Gundersen  
**Raintree View:** TBD  
**Duck Pond Activity Center:** Marilyn Burasco  
**Nominating:** David Elliott & Joan Bruns  
**Finance:** Marsha Powell  
**Siltation:** TBD  
**Welcoming:** Rose Marie Walter  
**Pond:** Roger Sense  
**Community Development:** Wanda Tyner  
**Security Committee:** David Mitchell  
**Social Media Committee:** Megan Gentile

**Committee Meetings  
& Locations:**

**ARB:** 1st & 3rd Mondays 7pm @ Clubhouse  
**Appeals:** 1st Tuesday 7pm @ DPAC  
**Common Ground:** 3rd Tuesday, 6:30pm @ DPAC  
**Lake:** 1st Monday 7pm @ Clubhouse  
**Pool:** 2nd Monday 7pm @ Clubhouse  
**Activities:** 2nd Thursday, 7:00 pm @ DPAC  
**Raintree View:** WATCH CALENDAR  
**Duck Pond Activity Center:** WATCH CALENDAR  
**Siltation:** WATCH CALENDAR  
**Pond:** WATCH CALENDAR  
**Community Development:** 4th Monday 7pm @  
Clubhouse

Double check calendar and dates as activity starts  
ramping up.

PreSort Standard  
U.S. Postage  
PAID  
Lee's Summit, MO  
Permit No. 9

## Contact Us

Raintree Lake Property  
Owners Association  
825 SW Raintree Dr.  
Office: 537-7576  
Fax: 537-5621

office@rlpoa.com,  
manager@rlpoa.com

Visit us on the web at  
www.rlpoa.com

OR CURRENT RESIDENT

**your  
neighborhood  
professionals...**

let us help you with your  
real estate and legal needs



**deb danaher**  
816-645-1633

go to [debdhomes.com](http://debdhomes.com) for your  
home search, home value, & market  
reports. Get a customized daily alert  
& be the first to see new homes.

[debdhomes@gmail.com](mailto:debdhomes@gmail.com)

**Paul Danaher**  
816-398-7365

Specializing in:  
- Accidents  
- Workers Compensation  
- Dangerous Products

